

19" SOUNDproof Free Standing Cabinets



19" SOUNDproof Free Standing Cabinets

Width: 750 mm
Depth: 1130 mm

SOUNDproof Free Standing Cabinets

General concept;
SOUNDproof Free Standing Cabinets for applications in office environments to reduce noise from active equipment, housed internally in the cabinet.

Available in 17U, 32U and 42U heights, width 750mm, depth 1130mm, ideal for the majority of data network, server and storage applications. SOUNDproof cabinets improve Health and Safety in the office environment by reducing noise and safe guarding office personal.

The Lande SOUNDproof cabinets has many applications with its superior sound reduction performance it allows IT equipment to be locally sited for optimum Network performance.

The product range has been developed for banks, hospitals, laboratories, hotels, meeting rooms, conference venues, with superior sound reduction performance.

The SOUNDproof cabinet is equipped with the most high performance silent fans and ventilation system, max 29-30dB levels, to support the main objective of noise reduction performance. Each cabinet is supplied as standard with a wooden concept finish on front and top cover, steel rear door and side panels, both front and rear doors are lockable.

SOUNDproof series has a professional aesthetic decorative wood finish on the front door and roof structure with steel rear door and side panels painted in RAL 9005 Black with fine wrinkle soft touch paint.

Completely standard and stocked product portfolio, delivered as a single piece assembled product with adjustable feet and heavy duty castor set included.

SOUNDproof series product range offers optional accessories to meet the specific requirements of users.

17U



32U



42U



19" SOUNDproof Free Standing Cabinets

Width: 750 mm
Depth: 1130 mm

Construction details:

Main frames;

Multi folded automated bending technology applied monoblock side panel/frame system, provides a heavy duty structure resulting in a high load capacity of 1000 kg.

Monoblock multi folded top and bottom cases, fixed to the side panel/frame system with fixing hardware, providing strength and rigidity.

Cable entry;

Bottom case integrated with wide cable entry point provides maximum versatility. The rubber edged sliding mechanism on the cable entry point at the base with $w=350\text{ mm} \times d=250\text{ mm}$ allows large cabling infrastructure applications. The rubber edged sliding mechanism max cable entry opening is $w=350 \times d=150\text{ mm}$. After inserting the cables, the rubber edged mechanism slides, holds and fixes the cables in parallel preventing dust entry.

Front door (high quality melamine coated chipboard);

Front door, wardrobe style double opening, 18 mm thickness, high quality melamine coated chipboard, with integrated barrel locking mechanism on top.

Rear door (solid metal);

Rear door, is double skin, metal, with acoustic sound emitting insulation material on the surface of both skins, integrated with handled locking unit.

Rear door also has a 3-way fan module. The hot air exhaust openings are available in both left and right sides of the rear door.

FAN module integration capacities per U height;

- 17U rear door, has 1x3 way thermostat controlled integrated fan module, with 2 pcs hot air exhaust openings included.
- 32U rear door, has 2x3 way thermostat controlled integrated fan module, with 4 pcs hot air exhaust openings included.
- 42U rear door, has 3x3 way thermostat controlled integrated fan module, with 6 pcs hot air exhaust openings included.



19" SOUNDproof Free Standing Cabinets

Width: 750 mm
Depth: 1130 mm

Construction Details:

Side Panels;

Narrow side panels; removable vertical side panels, which are lockable and removable with barrel locking. Side panels are also covered with acoustic sound emitting insulation material. Removable side panel allows access to vertical PDU housing.

The wide side panels form part of the main frame function of the enclosure which are double skin. Both skins of the panel are covered with acoustic sound emitting insulation material.

PDU integration and capacities per U height;

17U cabinet, has at both sides a 19" PDU vertical assembly location.

32U cabinet, has at both sides 2pcs 19" PDU vertical assembly location.

42U cabinet, has at both sides 2pcs 19" PDU vertical assembly location.

Vertical PDU's do not impede on U space, universal 19" standard PDU can be assembled at the 19" rails.

19" mounting rails;

19" rails of SOUNDproof Series Free Standing Cabinets are silk-screen printed with U numbering 1U to 42U, to help installation of equipment, same from top to bottom or bottom to top. 19" rails are 2.0 mm thickness, 4 fold bending surfaces for strength and high load capacities.

19" rails are made of steel with 8-12 micron zinc plating for corrosion resistance.

All 19" rails are adjustable in depth to allow flexibility when installing equipment.

Vertical cable management panels and brushed cable passage in front; SOUNDproof Cabinets have vertical cable management panel in front 1set=2pcs left/right.

Vertical cable management panels allow improved cable management with integrated aluminium rings 88x60 mm. Also there is 70x145 mm brushed cable passage openings inbetween the rings to allow cable bundles to the rear side of the cabinet.

19" SOUNDproof Free Standing Cabinets

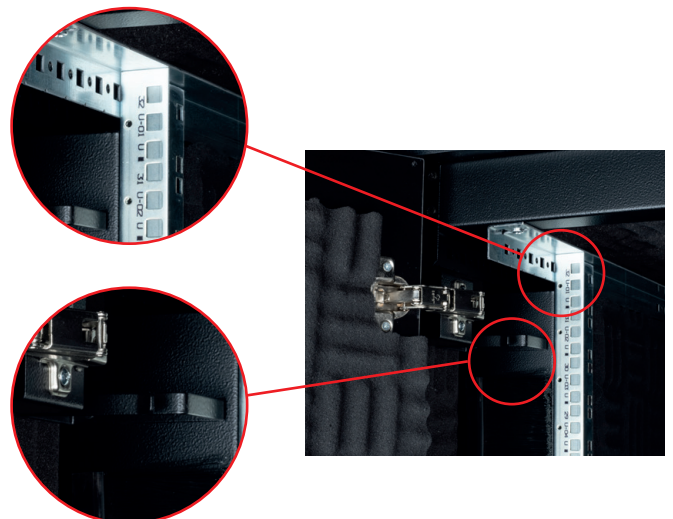

19" SOUNDproof Free Standing Cabinets

Width: 750 mm
Depth: 1130 mm

Construction details:

Top cover;

Top wood cover is 30 mm thickness, high quality melamine coated chipboard giving a professional appearance for the office environment.

For security the top cover is fixed from inside the cabinet and cannot be detached from outside.

Levelling feet, castor set;

The SOUNDproof Cabinet equipped with heavy duty castors and levelling feet. Once the cabinet is in position the adjustable levelling can be lowered and the cabinet is secured in position.

EN 14322; wood-based panels. Melamine faced boards for interior uses. Definition, requirements and classification; E1 quality level, formaldehyde emission E1 level, European Standard, classified as non Toxic. Indoor air concentration is less than 0,1 ppm (parts per million).



19" SOUNDproof Free Standing Cabinets

Width: 750 mm
Depth: 1130 mm

Construction details:

Acoustic Sound emitting insulation material;
High density sound emitting material, in medium, high and low frequency segments. Flexible with ventilation allowance hole spacing allows for best sound emitting performance.

- 75-100 kg/m³
- Non Flammable; (BS 476 Part 6 Class 0, Part 7 Class 1)
- Halogen Free
- Anti-Fungus
- For acoustic and sound emitting applications

Covers all doors and panels, inbetween the double skins and internal side of the inner skins.



Sound emitting performance;

8 servers in a standard cabinet

8 servers in a SOUNDproof cabinet

70dB			Sound level of vertical driller			70dB
60dB			Normal speech noise levels face to face			60dB
55dB						
50dB			Office background noise level			50dB
			SOUNDproof Cabinet			
40dB						40dB
Silent room						Silent room

18-21 dB noise level reduction from 1 meter distance to the enclosure

All design features provide strength and 4 way access to equipment, easy for installations and maintenance needs whilst providing the best sound emitting performance.

19" SOUNDproof

Free Standing Cabinets

Concept Drawings

Lock, cable entry, castor set, leveling feet, hot air exhaust

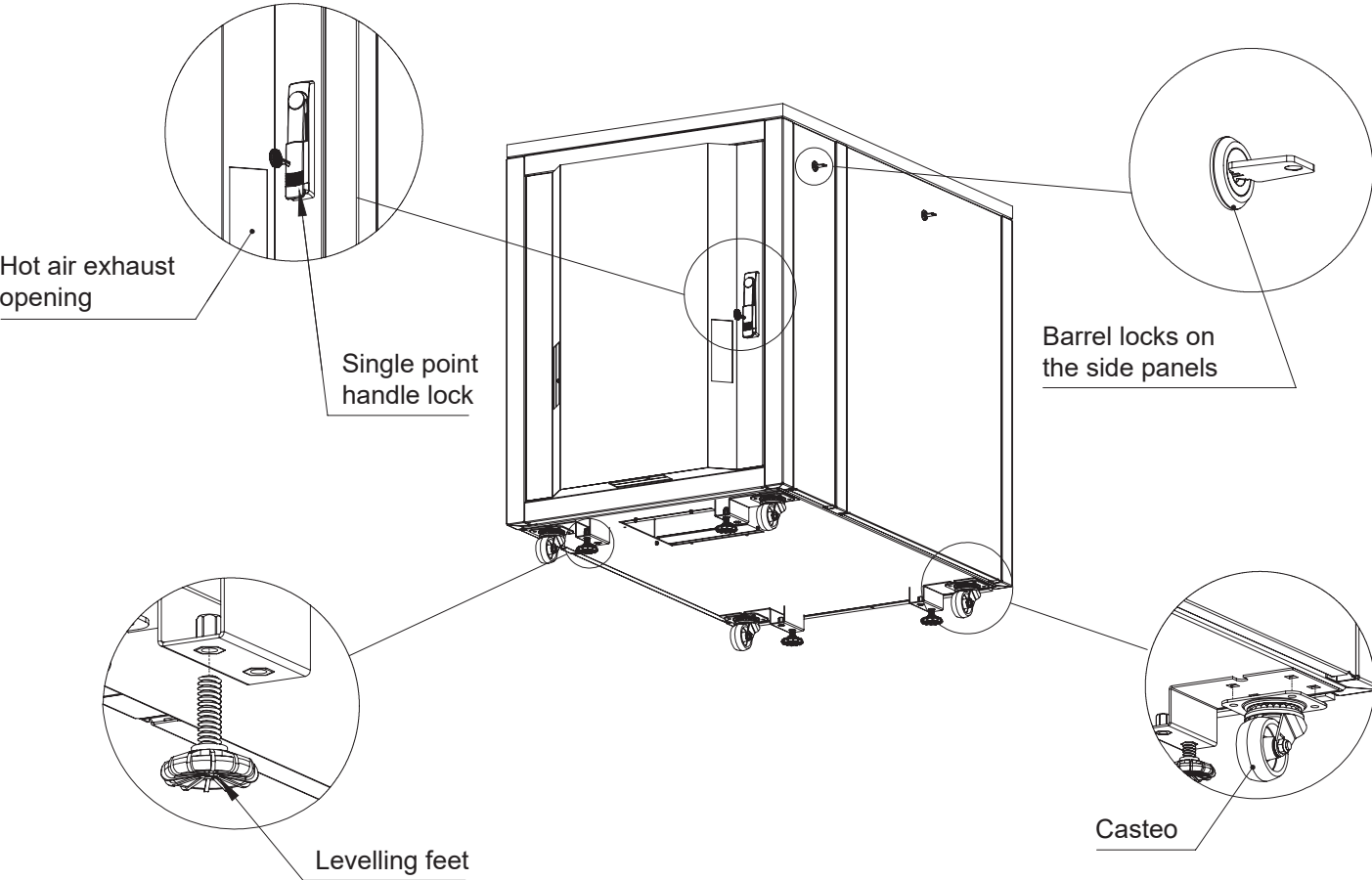

19" SOUNDproof Free Standing Cabinets Concept Drawings

Fan system, cable passage brushes, cable management rings

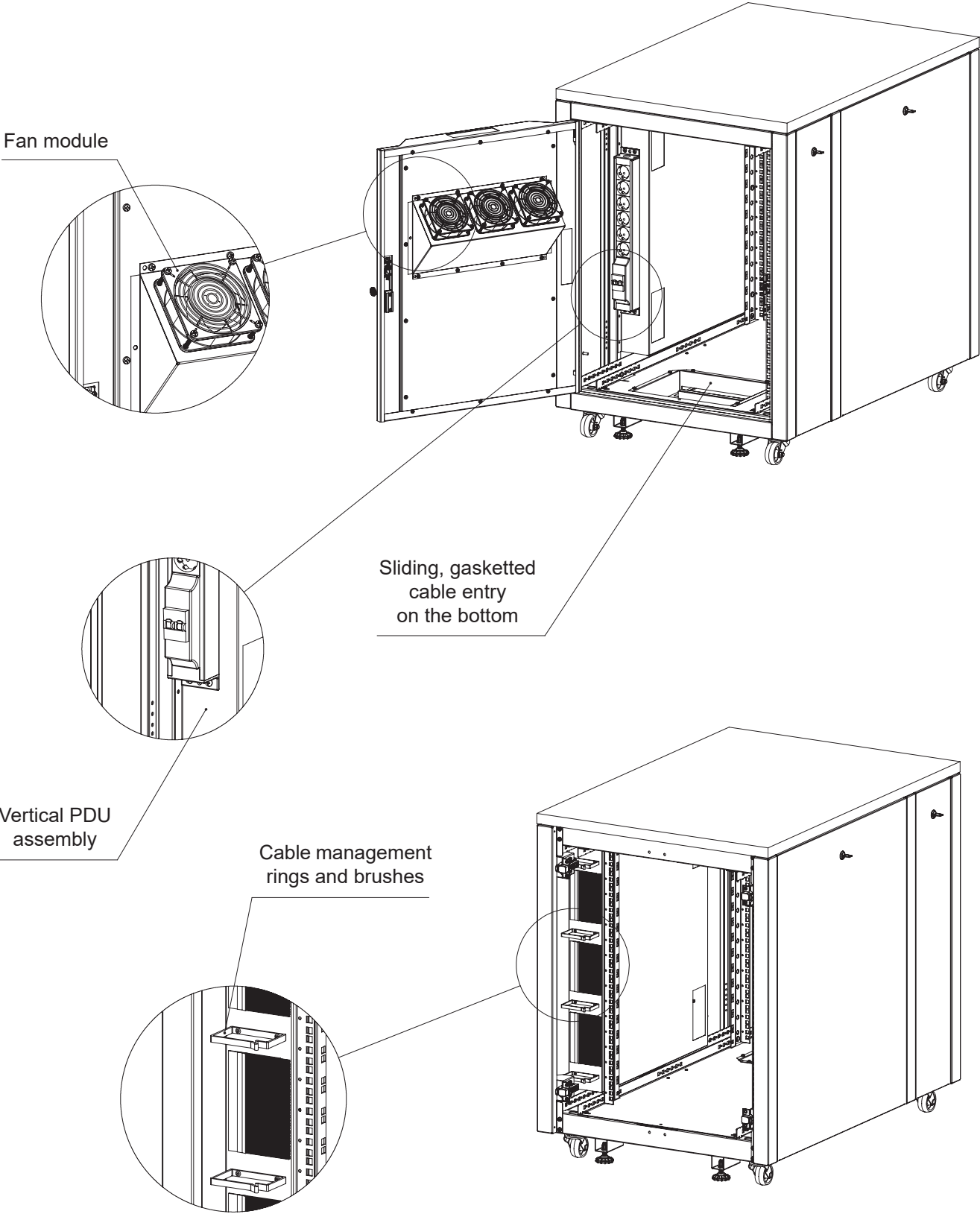

19" SOUNDproof

Free Standing Cabinets

U Heights: 17U, 32U and 42U

Width: 750 mm
Depth: 1130 mm

Load Capacity: 1000 kgs.

U Height: 17U

Standards and Compliances:



ISO 9001:2008
Quality Management System

EN 61587-1:2012
Mechanical Structures for
Electronic Equipment

IEC 297-1, 19" Mounting
IEC 297-2 Overall Cabinet Dimensions



CE conform to
EN 60950-1:2006
Information Technology
Equipment-Safety-Part-1-
General Requirement



UL listed to
UL 2416, Outline of Investigation
for Audio/Video, Information and
Communication Technology Equipment
Cabinet, Enclosure and Rack Systems;
UL 60950-1 and CSA C22.2 NO.
60950-1-07, Information Technology
Equipment Safety Part 1: General
Requirements



Environment Friendly;
* ISO 14001 Environmental
Management System
* RoHS compliancy
* %100 Recyclable Material

Standard Colour of Metal Parts:



RAL 9005 Black

SOUNDproof free standing cabinets, with 19" w:750 mm and d:1130 mm physical sizes, with max internal usable depth 17U.



19" SOUNDproof Free Standing Cabinets 17U Drawings

Width: 750 mm
Depth: 1130 mm

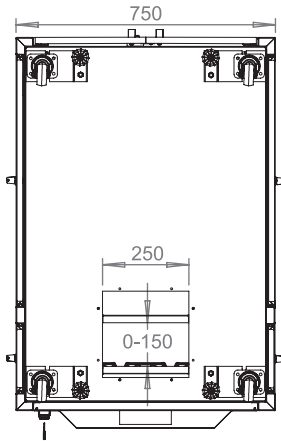

Bottom view

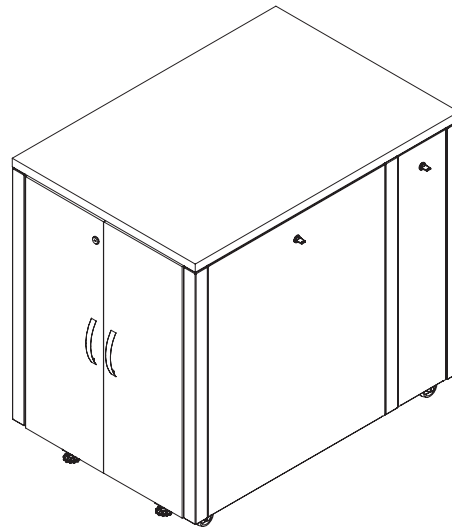

Isometric view

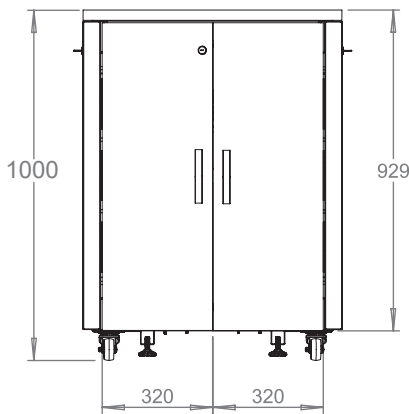

Front view

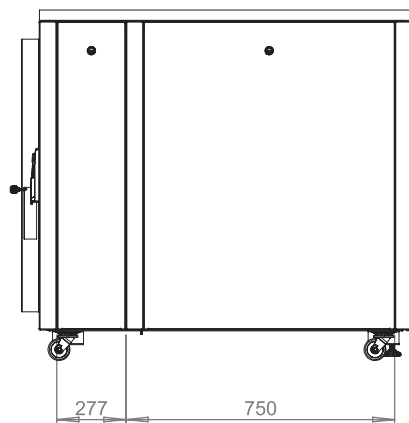

Side view

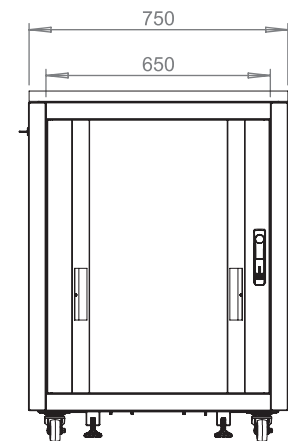

Rear view

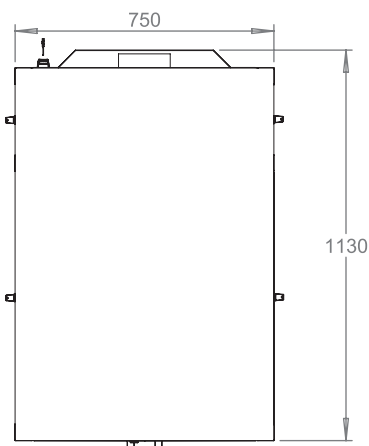

Top view

19" SOUNDproof

Free Standing Cabinets 17U

Drawings

Width: 750 mm
Depth: 1130 mm

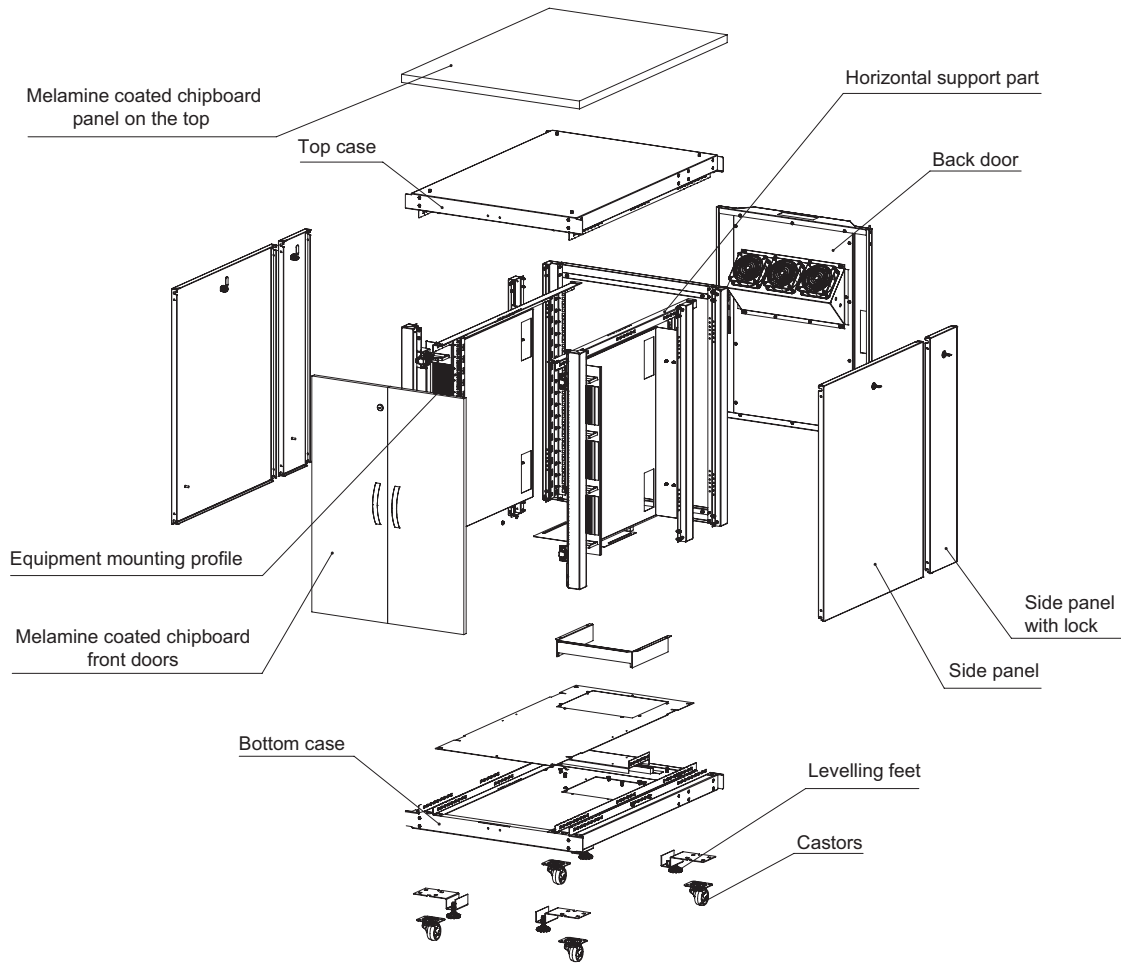

Exploded view

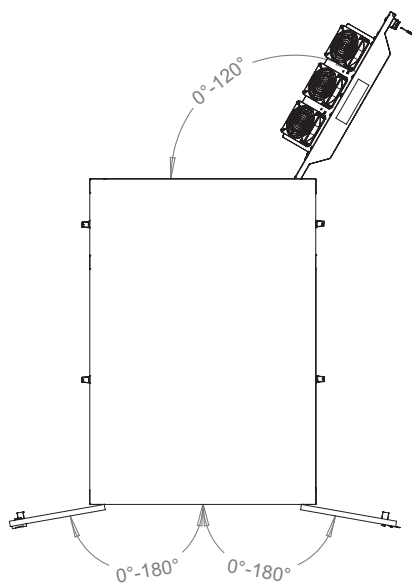

Front door opening angle

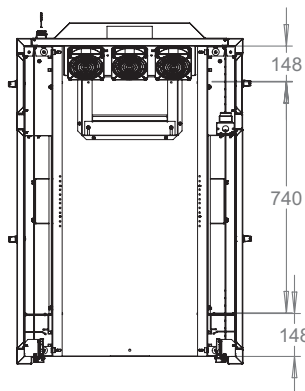

Equipment mounting distance

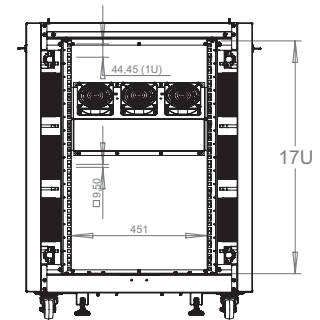

Dimensions in width and height

19" SOUNDproof

Free Standing Cabinets 17U

Drawings

Width: 750 mm
Depth: 1130 mm

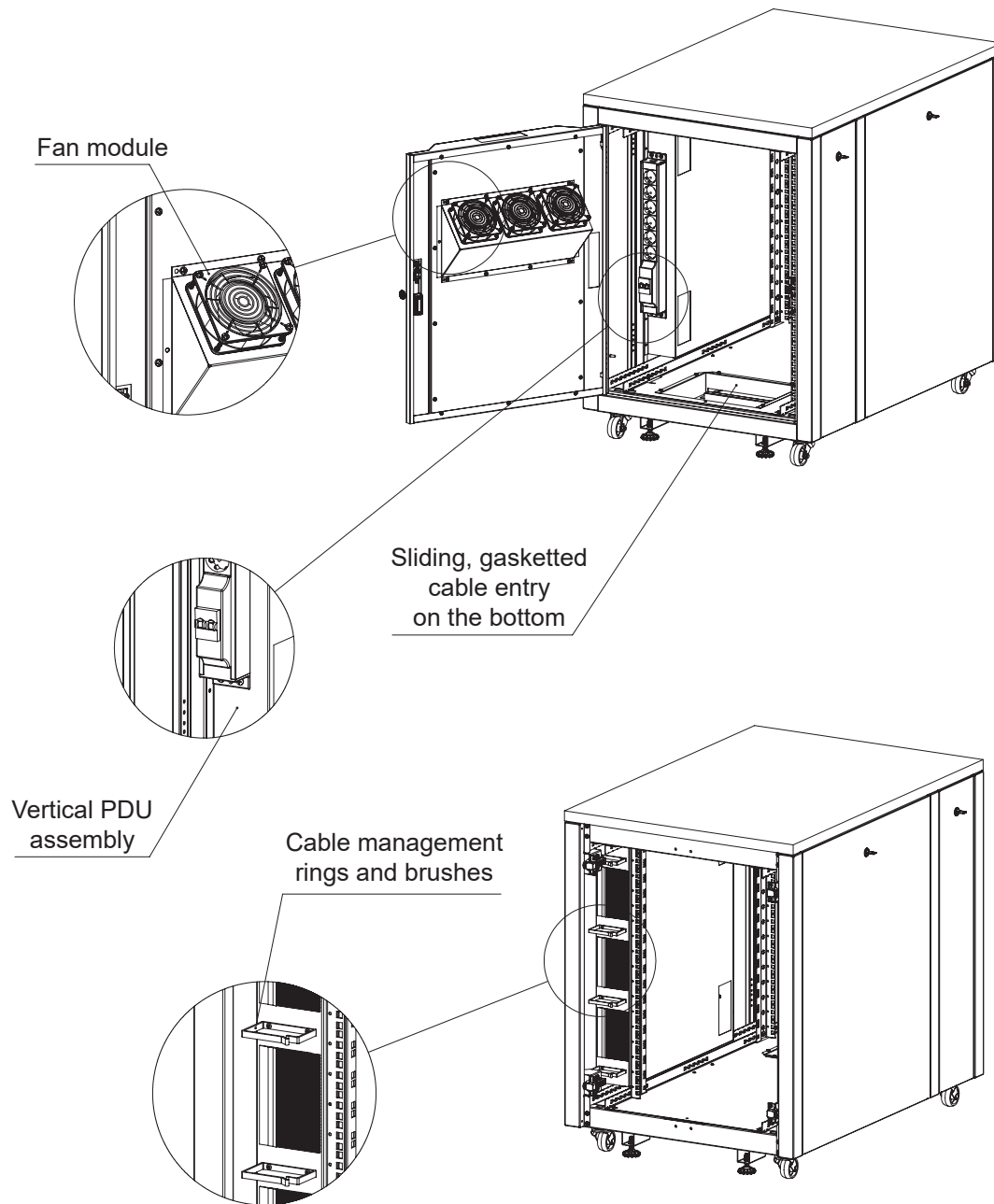

SOUNDproof Series Free Standing 19" Cabinets 17U W=750 mm D=1130 mm

Product Number**	Product Description	Size WxDxH mm	h Size in U	h in mm	H mm, Overall Incl Feet, Castor	Width Overall mm	Width Rail to Rail	Depth Overall mm	Depth Shipping Conf. Rail to Rail mm	QTY IN PACKAGE	PACKING DIMENSIONS WxDxH mm	Standard NET Weight of Product kgs	Gross Weight of Product kgs	QTY IN PALETTE
LN-SP-17U7511-B-BL	17U 19" SOUNDproof Cabinet W=750 mm D=1130 mm	750x1130x1000	17U	756	1000	750	19"	1130	740	1	820x1200x1120	138	52	1

* Standard supply is with B-Black Wood/Furniture Concept

*** All metallic parts are in RAL 9005 Black Colour, any other colour requests, please have a correspondence.

19" SOUNDproof

Free Standing Cabinets

U Heights: 17U, 32U and 42U

Width: 750 mm
Depth: 1130 mm

Load Capacity: 1000 kgs.

U Height: 32U

Standards and Compliances:



ISO 9001:2008
Quality Management System

EN 61587-1:2012
Mechanical Structures for
Electronic Equipment

IEC 297-1, 19" Mounting
IEC 297-2 Overall Cabinet Dimensions



CE conform to
EN 60950-1:2006
Information Technology
Equipment-Safety-Part-1-
General Requirement



UL listed to
UL 2416, Outline of Investigation
for Audio/Video, Information and
Communication Technology Equipment
Cabinet, Enclosure and Rack Systems;
UL 60950-1 and CSA C22.2 NO.
60950-1-07, Information Technology
Equipment Safety Part 1: General
Requirements



Environment Friendly;
* ISO 14001 Environmental
Management System
* RoHS compliancy
* %100 Recyclable Material

Standard Colour of Metal Parts:



RAL 9005 Black

SOUNDproof free standing cabinets, with 19" w: 750 mm and d: 1130 mm physical sizes, with max internal usable depth 32U.



19" SOUNDproof

Free Standing Cabinets 32U

Drawings

Width: 750 mm
Depth: 1130 mm

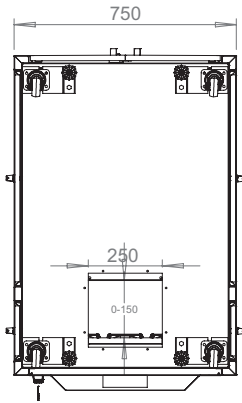

Bottom view

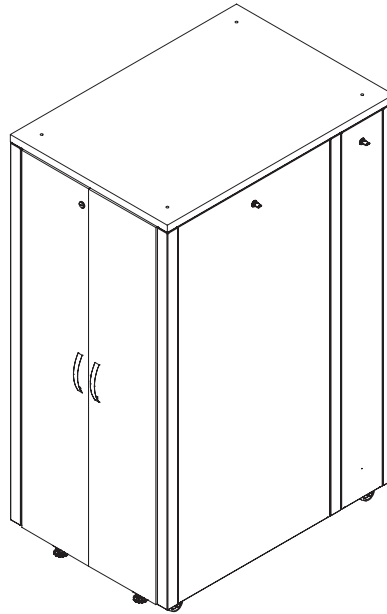

Isometric view

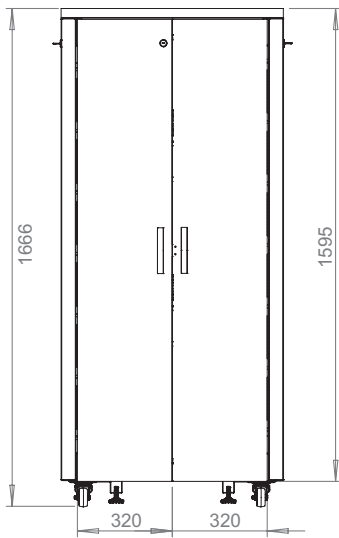

Front view

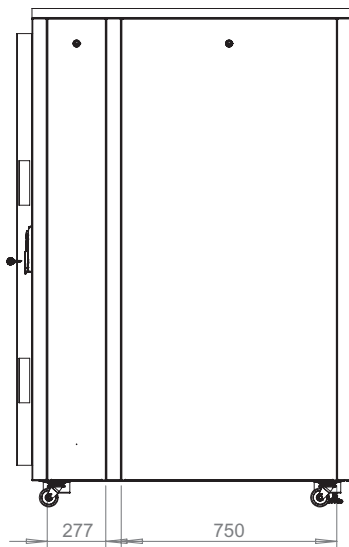

Side view

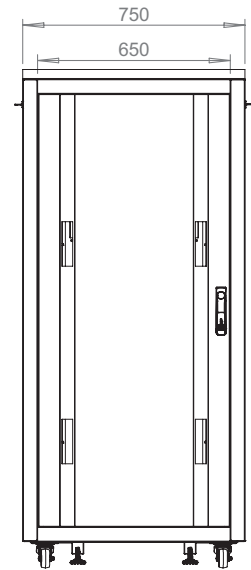

Rear view

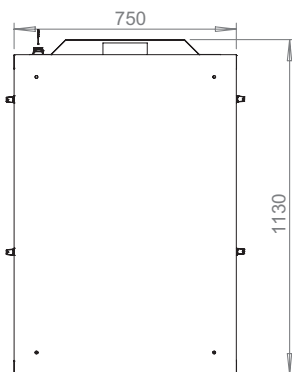

Top view

19" SOUNDproof

Free Standing Cabinets 32U

Drawings

Width: 750 mm
Depth: 1130 mm

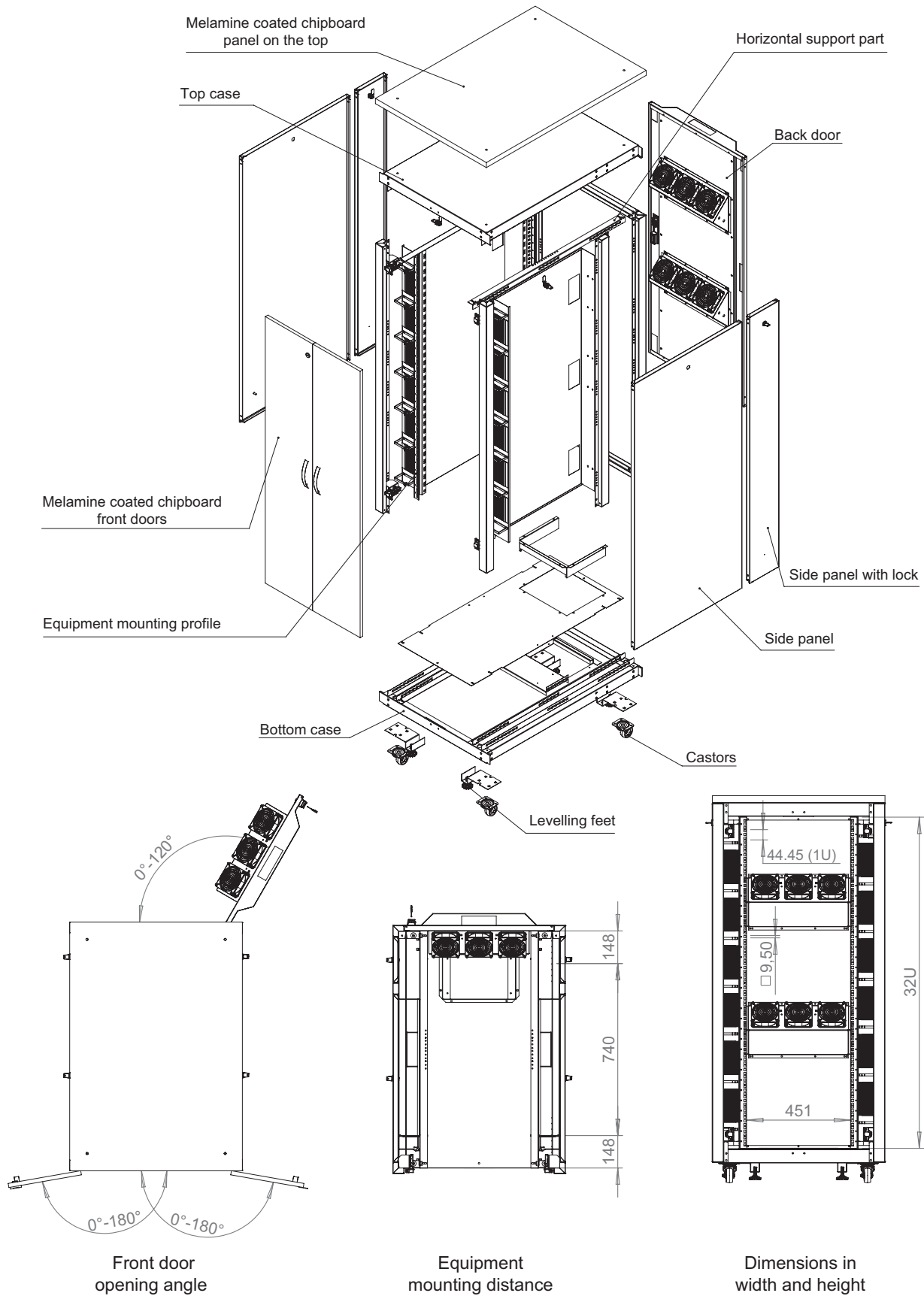

19" SOUNDproof

Free Standing Cabinets 32U

Drawings

Width: 750 mm
Depth: 1130 mm

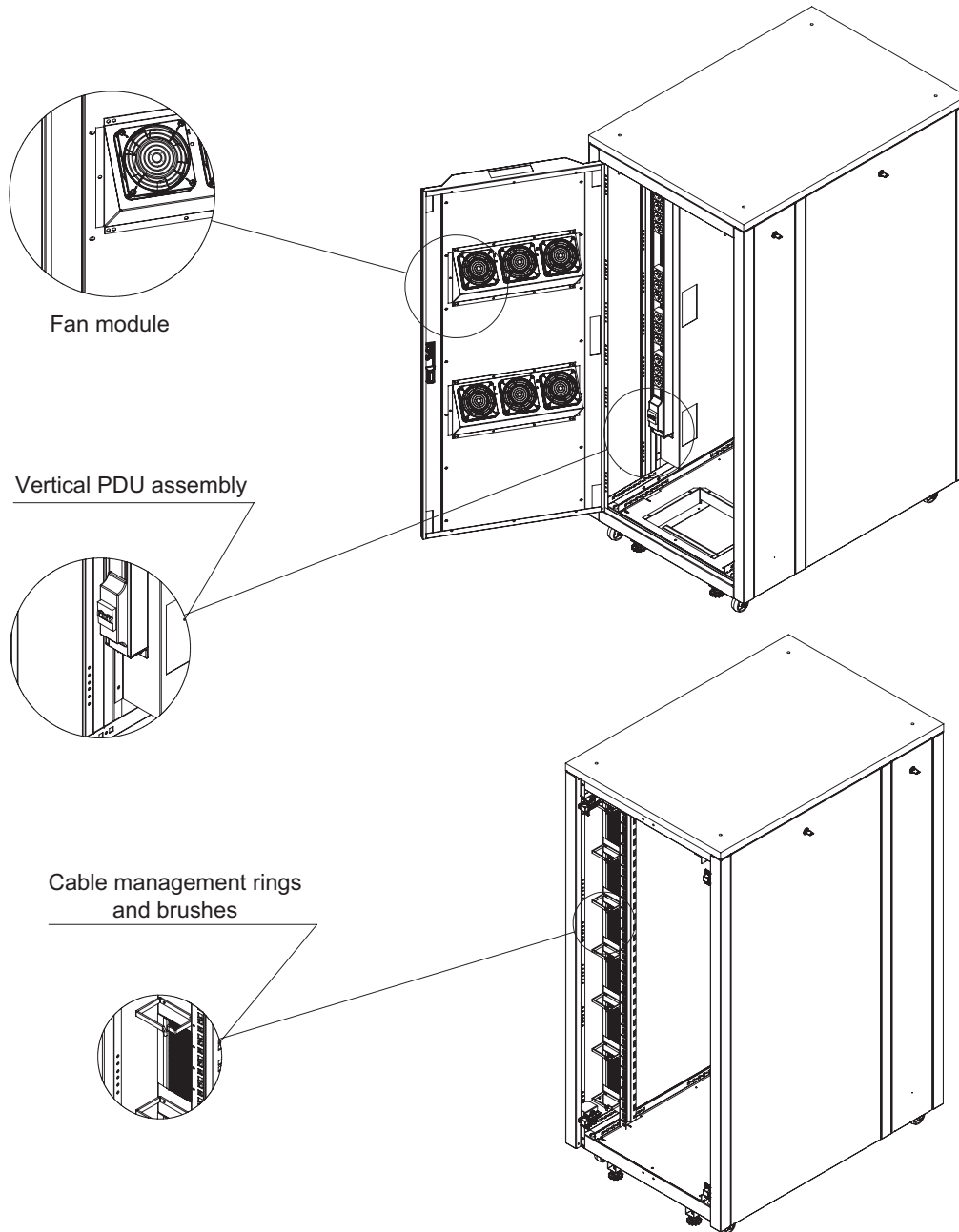

SOUNDproof Series Free Standing 19" Cabinets 32U W=750 mm D=1130 mm

Product Number**	Product Description	Size WxDXH mm	h Size in U	h in mm	H mm, Overall Incl Feet, Castor	Width Overall mm	Width Rail to Rail	Depth Overall mm	Depth Shipping Conf. Rail to Rail mm	QTY IN PACKAGE	PACKING DIMENSIONS WxDXH mm	Standard NET Weight of Product kgs	Gross Weight of Product kgs	QTY IN PALETTE
LN-SP-32U7511-B-BL	32U 19" SOUNDproof Cabinet W=750 mm D=1130 mm	750x1130x1666	32U	1423	1666	750	19"	1130	740	1	820x1200x1787	165	183	1

* Standard supply is with B-Black Wood/Furniture Concept

** All metallic parts are in RAL 9005 Black Colour, any other colour requests, please have a correspondence.

19" SOUNDproof

Free Standing Cabinets

U Heights: 17U, 32U and 42U

Width: 750 mm
Depth: 1130 mm

Load Capacity: 1000 kgs.

U Height: 42U

Standards and Compliances:



ISO 9001:2008
Quality Management System

EN 61587-1:2012
Mechanical Structures for
Electronic Equipment

IEC 297-1, 19" Mounting
IEC 297-2 Overall Cabinet Dimensions



CE conform to
EN 60950-1:2006
Information Technology
Equipment-Safety-Part-1-
General Requirement



UL listed to
UL 2416, Outline of Investigation
for Audio/Video, Information and
Communication Technology Equipment
Cabinet, Enclosure and Rack Systems;
UL 60950-1 and CSA C22.2 NO.
60950-1-07, Information Technology
Equipment Safety Part 1: General
Requirements



Environment Friendly;
* ISO 14001 Environmental
Management System
* RoHS compliancy
* %100 Recyclable Material

Standard Colour of Metal Parts:



RAL 9005 Black

SOUNDproof free standing cabinets, with 19" w: 750 mm and d: 1130 mm physical sizes, with max internal usable depth 42U.



19" SOUNDproof Free Standing Cabinets 42U Drawings

Width: 750 mm
Depth: 1130 mm

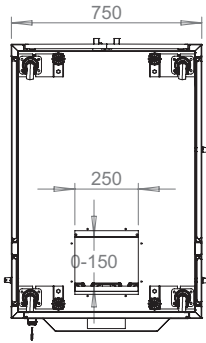

Bottom view

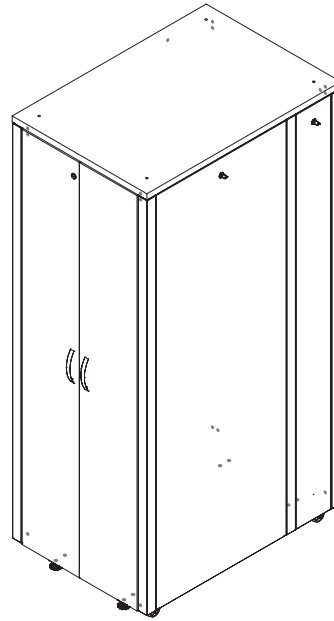

Isometric view

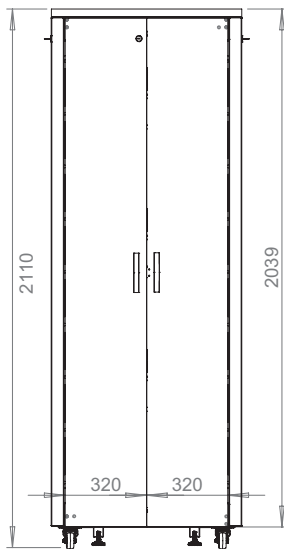

Front view

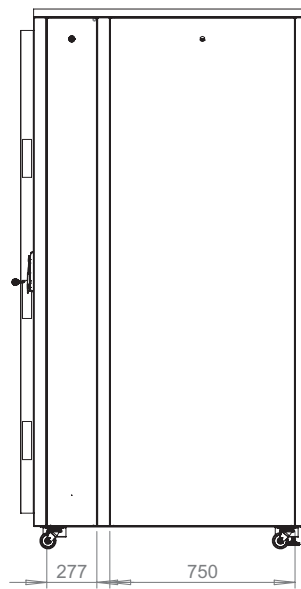

Side view

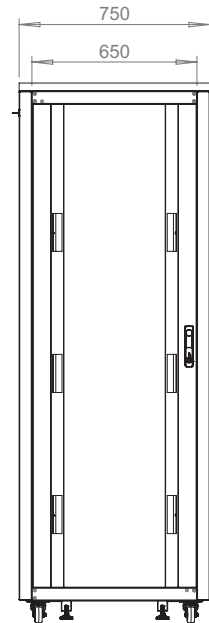

Rear view

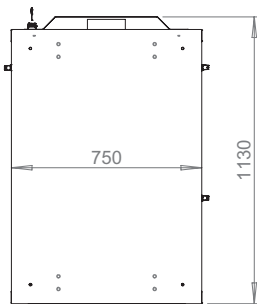

Top view

19" SOUNDproof

Free Standing Cabinets 42U

Drawings

Width: 750 mm
Depth: 1130 mm

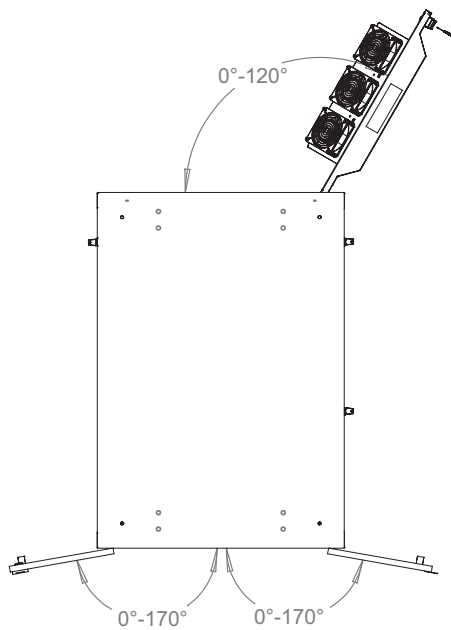
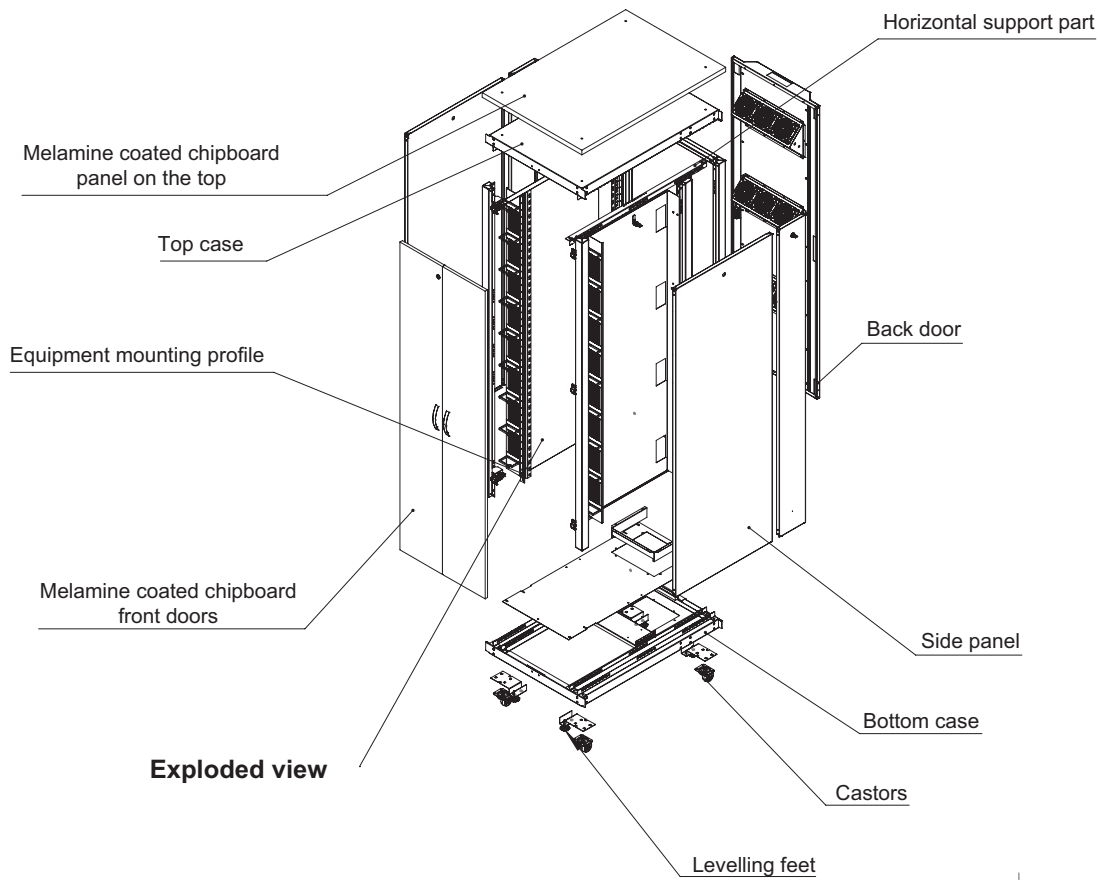

Front door opening angle

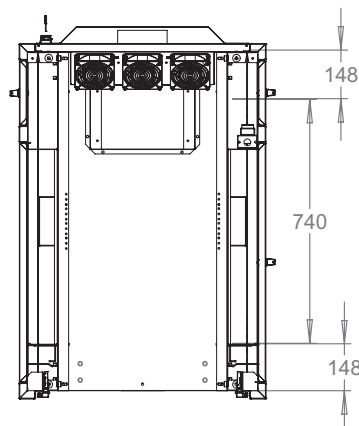

Equipment mounting distance

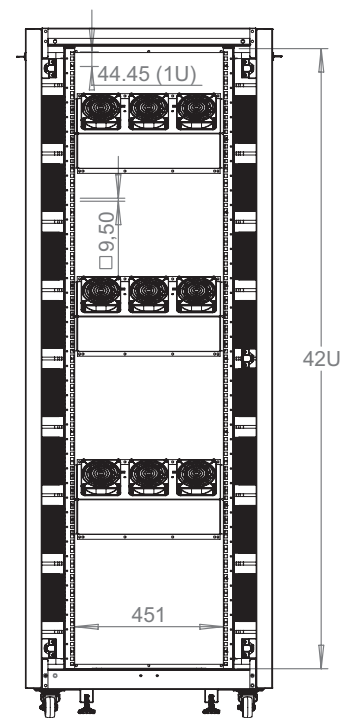

Dimensions in width and height

19" SOUNDproof

Free Standing Cabinets 42U

Drawings

Width: 750 mm
Depth: 1130 mm

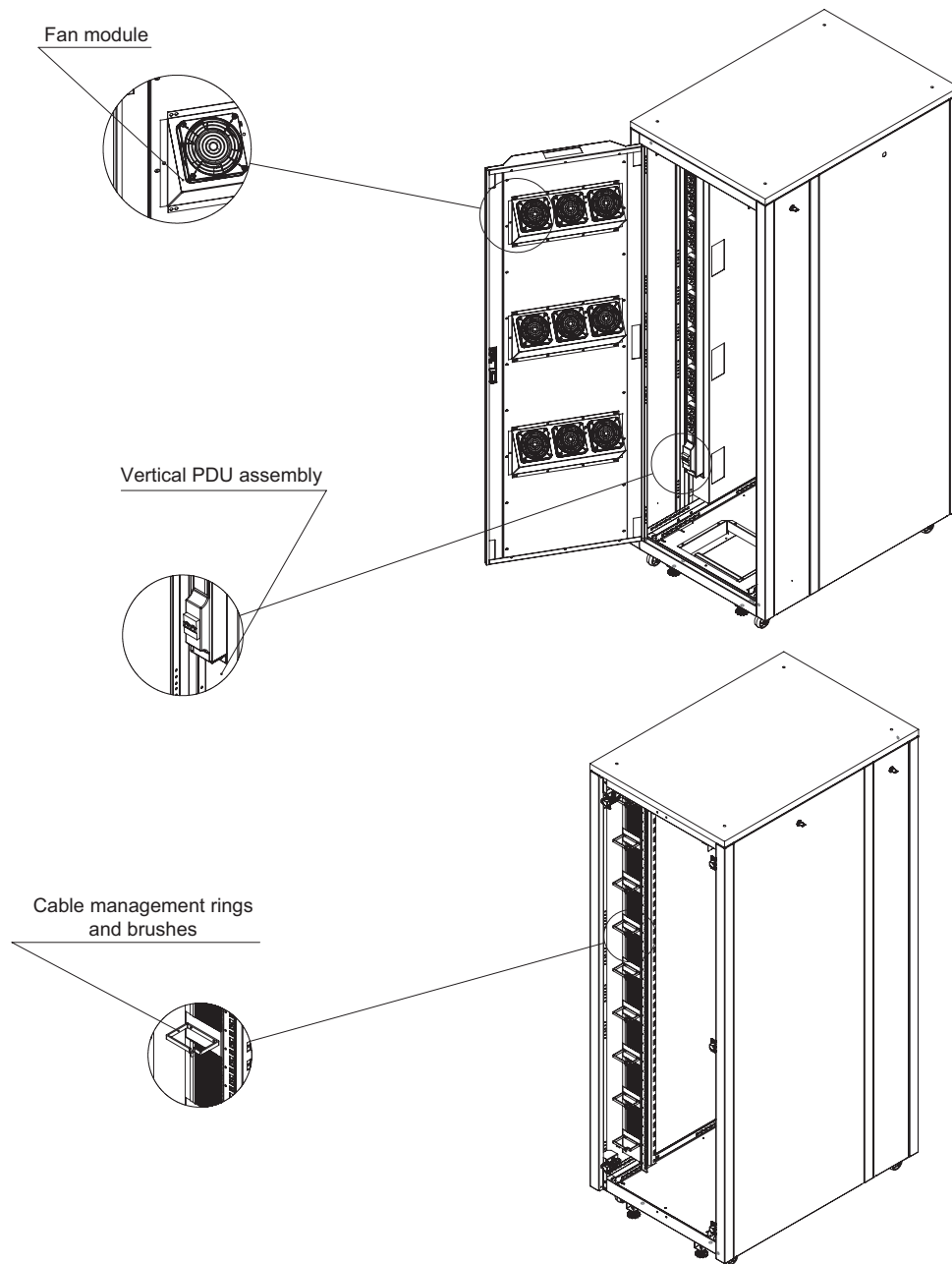

SOUNDproof Series Free Standing 19" Cabinets 42U W=750 mm D=1130 mm

Product Number	Product Description	Size WxDXH mm	h Size in U	h in mm	H mm, Overall Incl Feet, Castor	Width Overall mm	Width Rail to Rail	Depth Overall mm	Depth Shipping Conf. Rail to Rail mm	QTY IN PACKAGE	PACKING DIMENSIONS WxDXH mm	Standard NET Weight of Product kgs	Gross Weight of Product kgs	QTY IN PALETTE
LN-SP-42U7511-B-BL	42U 19" SOUNDproof Cabinet W=750 mm D=1130 mm	750x1130x2110	42U	1867	2110	750	19"	1130	740	1	820x1200x2231	210	228	1

* Standard supply is with B-Black Wood/Furniture Concept

** All metallic parts are in RAL 9005 Black Colour, any other colour requests, please have a correspondence.



www.comtecdirect.co.uk

Comtec Huntingdon

Head Office and Main Distribution Centre
Cardinal Way
Cardinal Distribution Park
Godmanchester
Huntingdon
England
PE29 2XJ
Phone: +44 (0)1480 415000
Email: sales@comtecdirect.co.uk

Comtec Glasgow

Trade Counter & Sales Office
20 Couper Street
Glasgow
G4 ODL
Phone: +44 (0)141 564 1234
Email: glasgow@comtecdirect.co.uk